

### Introduction

**DRAGON** UV-Series Screening ceiling system is an open space design. The entire ceiling is suspended by the special-made runner. In order to cooperate with the requirement of multiplication design, length and spacing of each panel can be provided custom ordering. The panel is easy to be assembled and disassembled by person in order to simplify the further inspection of equipments like light fittings, and other additional components.

### 產品介紹

**天龍牌** UV-系列 垂直片型掛式天花系統是一種開放式的天花設計，由特製的龍骨懸掛整幅天花。為配合多元化的設計需求，天花片的間距及長度可按照實際情況需要而訂製，天花的安裝及拆卸的工序十分簡單，方便於後期於天花背後的設備檢查及維修。

### Panel

Pattern: Floating sheet/Strip.

Materials: Aluminum alloy.

Feature: Plain or curved surface and custom panel length is also available for various design requirements. (FIG. A)

### 天花片

外型：片型/條型。

物料：鋁合金。

特徵：平面、具曲線的表面及天花片的長度可按不同的設計要求訂製。(圖A)

### Coating

Electrostatics powder-coating with Pure white-2112 (RAL9010), Traffic white-2111 (RAL9016) or Standard white-2113 and many colour available.

### 表面處理

象牙白-2112 (RAL9010)、訊號白-2111 (RAL9016) 及標準白-2113的靜電粉末噴塗及有其他不同的顏色可供選擇。



### Suspension

The ceiling is suspended by UV Runner (UV-101) with screw rod. The distance between each runner is about 1200mm centre to centre. Runner connector (UV-102) is used to extend the length of runner (FIG. C). The runner made from either aluminum alloy or galvanized steel.

### 吊掛系統

圖B所示，該系統的天花主要由UV龍骨(UV-101)配合螺絲杆懸掛整幅天花，每支龍骨的距離中至中為1200mm。在圖C中，使用龍骨駁碼(UV-102)將各龍骨連接在一起，把龍骨的長度不斷地伸延。龍骨所用之物料可選用鋁合金或鍍鋅鋼材。

| Model No.<br>型號 | Dimension<br>規格尺寸 |
|-----------------|-------------------|
| UV-100          | H100xLmm          |
| UV-150          | H150xLmm          |

Special dimension can be ordered according to the enquiry of Designers, Architects and Consultants. 可根據設計師、建築師及專業顧問的需求訂製該系列特別尺寸的天花產品。

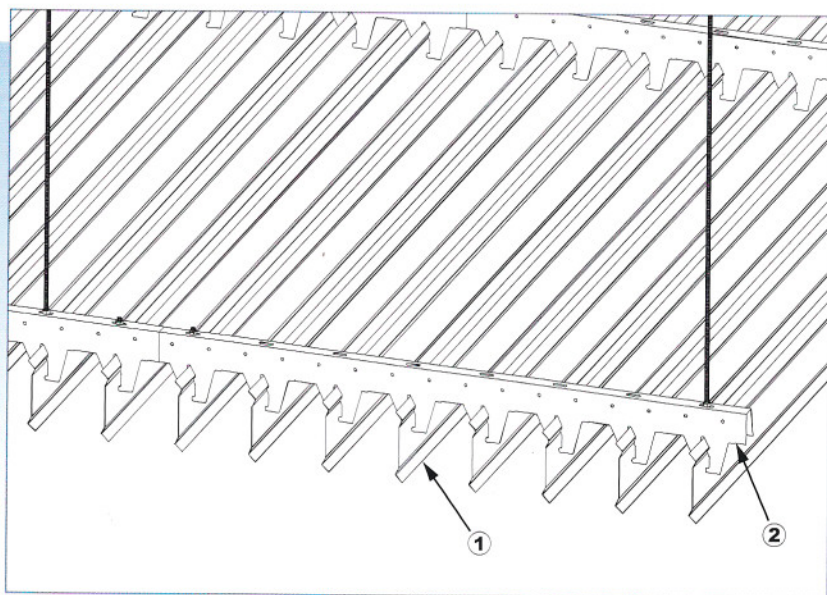

Suspension Drawing : Screening Ceiling System  
吊掛示意圖：垂直片型掛式天花系統

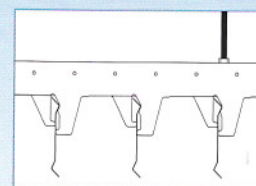

Fig.A  
圖A

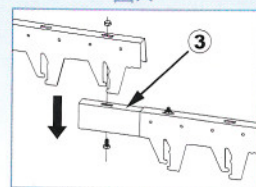

Fig.C  
圖C

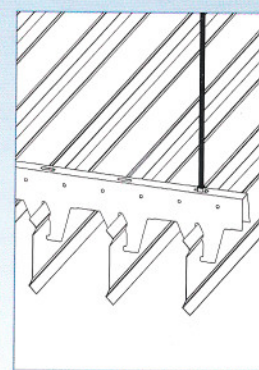

Fig.B  
圖B

Screening Ceiling System 垂直片型掛式天花系統

- |                              |        |
|------------------------------|--------|
| 1. UV Ceiling Panel          | UV條型天花 |
| 2. UV Runner (UV-101)        | UV龍骨   |
| 3. Runner Connector (UV-102) | UV龍骨駁碼 |