

BO/BA-series

Linear Ceiling System 條型天花系統

DRAGON[®]
BUILDING MATERIAL PRODUCT

Introduction

DRAGON BO/BA-Series Linear ceiling system is a closed space design. It is suitable for the narrow spatial use. The panel is laid on the side wall angle. The installment and disassembling is extremely simple. Coordinates DRAGON special light fittings and air-diffusers can make the best performance in ceiling outwards.

產品介紹

天龍牌 BO/BA-系列 條型天花系統是一種密閉式的天花設計，適合於狹窄的空間使用，天花板放置於兩側的牆身角之上，安裝及拆卸均十分簡便。如配合天龍牌的專用燈具及風咀，可以令整體天花的外觀達致最佳的效果。

Panel

Pattern: Strip.

Materials: Aluminum alloy/Galvanized steel.
Feature: The two edges of panel are 90° squared (BO-series) or 45° beveled (BA-series) design. (FIG. A)

天花片

外型：條形。

物料：鋁合金/鍍鋅鐵。

特徵：天花片的兩邊為90度直邊(BO系列)或45度斜邊(BA系列)設計。(圖A)

Coating

Electrostatics powder-coating with Pure white-2112 (RAL9010), Traffic white-2111 (RAL9016) or Standard white-2113 and many colour available.

表面處理

象牙白-2112 (RAL9010)、訊號白-2111(RAL9016)及標準白-2113的靜電粉末噴塗及有其他不同的顏色可供選擇。



Suspension

There are two kinds of suspension system (without or with runner). Without runner type, L-angle, W-angle and others profile wall angle is used to suspend the entire ceiling. With runner type, the U-shape runner is assembled at the back of the ceiling to increase the flatness of the ceiling. All of the suspension units made from galvanized steel.

吊掛系統

該系統的吊掛形式分為免龍骨及具有龍骨吊掛兩類。免龍骨吊掛利用兩側的L角、W角或其他款式的牆身角承托整幅天花。具有龍骨吊掛形式的天花背面裝置了U型龍骨，提升了天花表面的平整度。所有吊掛系統配件之物料均選用鍍鋅鋼材。

Perforation

Many perforation patterns available.

| Model No. 型號 | Dimension 規格尺寸 |
|-----------------|-------------------|
| BO-150 | W150xLmm |
| BO-200 | W200xLmm |
| BO-300 | W300xLmm |
| BA-150 | W150xLmm |
| BA-200 | W200xLmm |
| BA-300 | W300xLmm |

Special dimension can be ordered according to the enquiry of Designers, Architects and Consultants. 可根據設計師、建築師及專業顧問的需求訂製該系列特別尺寸的天花產品。

佈孔形式

多款佈孔形式提供選擇。

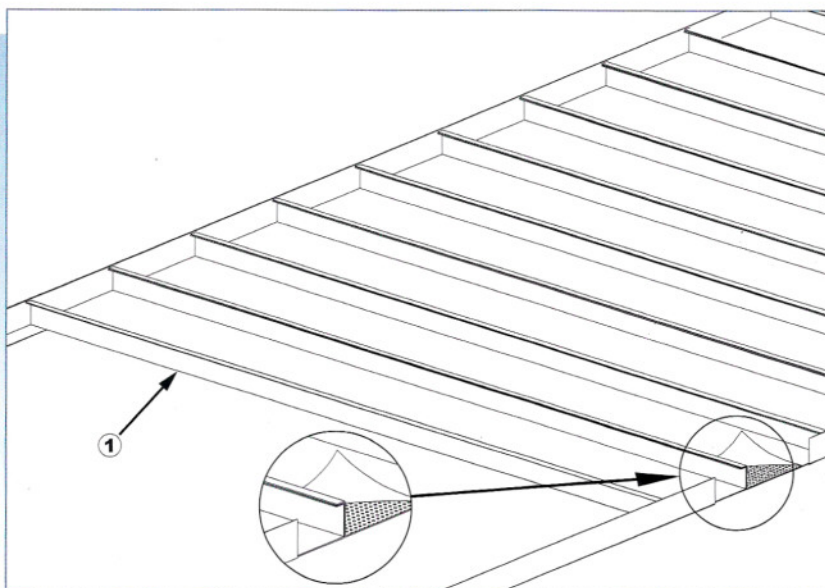

Suspension Drawing : Linear Ceiling System
吊掛示意圖：條型天花系統

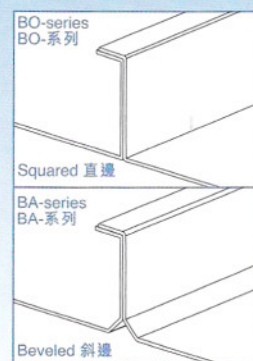

Fig.A
圖A

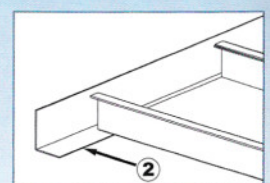

Fig.B
圖B

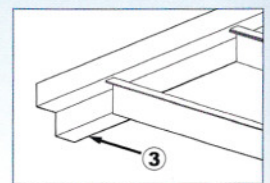

Fig.C
圖C

Linear Ceiling System

條型天花系統

1. Ceiling Panel
2. L-angle (L-40/L-50)
3. W-angle (W-80)

條型天花板
L角
W角